

80V N-Ch Power MOSFET

L L
LM M

V_{DS}		80	V
$R_{DS(on),typ}$	$V_{GS}=10V$	9.5	m
$R_{DS(on),typ}$	$V_{GS}=4.5V$	13.5	m
I_D (Silicon Limited)		12	A

L L L L
L M

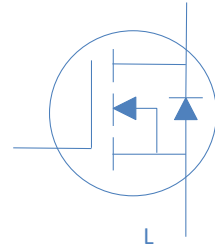

Part Number	Package	Marking
HGS110N08AL	SOIC-8	GS110N08AL

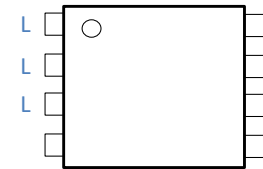

Absolute Maximum Ratings at T_j

Parameter	Symbol	Conditions	Value	Unit
Continuous Drain Current (Silicon Limited)	I_D	T_C	12	A
		T_C	8	
Drain to Source Voltage	V_{DS}	-	80	V
Gate to Source Voltage	V_{GS}	-	20	V
Pulsed Drain Current	I_{DM}	-	56	A
Avalanche Energy, Single Pulse	E_{AS}	$L=0.4mH, T_C$	45	mJ
Power Dissipation	P_D	T_C	3.1	W
Operating and Storage Temperature	T_J, T_{stg}	-	-55 to 150	

Absolute Maximum Ratings

Parameter	Symbol	Max	Unit
Thermal Resistance Junction-Lead	R_{JL}	25	
Thermal Resistance Junction-Ambient (steady state)	R_{JA}	40	
		75	

Electrical Characteristics at T_j
Static Characteristics

Parameter	Symbol	Conditions	Value			Unit
			min	typ	max	
Drain to Source Breakdown Voltage	$V_{(BR)DSS}$	$V_{GS}=0V, I_D=250\text{ A}$	80	-	-	V
Gate Threshold Voltage	$V_{GS(th)}$	$V_{GS}=V_{DS}, I_D=250\text{ A}$	1.0	1.9	2.4	
Zero Gate Voltage Drain Current	I_{DSS}	$V_{GS}=0V, V_{DS}=80V, T_j$	-	-	1	A
		$V_{GS}=0V, V_{DS}=80V, T_j$	-	-	100	
Gate to Source Leakage Current	I_{GSS}	$V_{GS} \quad \quad \quad V_{DS}=0V$	-	-	100	nA
Drain to Source on Resistance	$R_{DS(on)}$	$V_{GS}=10V, I_D=10A$	-	9.5	11.5	m
	$R_{DS(on)}$	$V_{GS}=4.5V, I_D=5A$	-	13.5	16	m
Transconductance	g_{fs}	$V_{DS}=5V, I_D=10A$	-	40	-	S
Gate Resistance	R_G	$V_{GS}=0V, V_{DS}\text{ Open}, f=1\text{MHz}$	-	1.3	-	

Dynamic Characteristics

Input Capacitance	C_{iss}	$V_{GS}=0V, V_{DS}=40V, f=1\text{MHz}$	-	1131	-	pF
Output Capacitance	C_{oss}		-	205	-	
Reverse Transfer Capacitance	C_{riss}		-	8.5	-	
Total Gate Charge	$Q_g(10V)$	$V_{DD}=40V, I_D=10A, V_{GS}=10V$	-	23	-	nC
Total Gate Charge	$Q_g(4.5V)$		-	12.5	-	
Gate to Source Charge	Q_{gs}		-	3	-	
Gate to Drain (Miller) Charge	Q_{gd}		-	6	-	
Turn on Delay Time	$t_{d(on)}$	$V_{DD}=40V, I_D=10A, V_{GS}=10V, R_G=10\text{ }\Omega$	-	8	-	ns
Rise time	t_r		-	3	-	
Turn off Delay Time	$t_{d(off)}$		-	22	-	
Fall Time	t_f		-	4	-	

Reverse Diode Characteristics

Diode Forward Voltage	V_{SD}	$V_{GS}=0V, I_F=20A$	-	0.9	1.2	V
Reverse Recovery Time	t_{rr}	$V_R=40V, I_F=10A, dI_F/dt=100A/\text{s}$	-	35	-	ns
Reverse Recovery Charge	Q_{rr}		-	30	-	nC

Fig 1. Typical Output Characteristics

Figure 2. On-Resistance vs. Gate-Source Voltage

Figure 3. On-Resistance vs. Drain Current and Gate Voltage

Figure 4. Normalized On-Resistance vs. Junction Temperature

Figure 5. Typical Transfer Characteristics

Figure 6. Typical Source-Drain Diode Forward Voltage

Figure 7. Typical Gate-Charge vs. Gate-to-Source Voltage

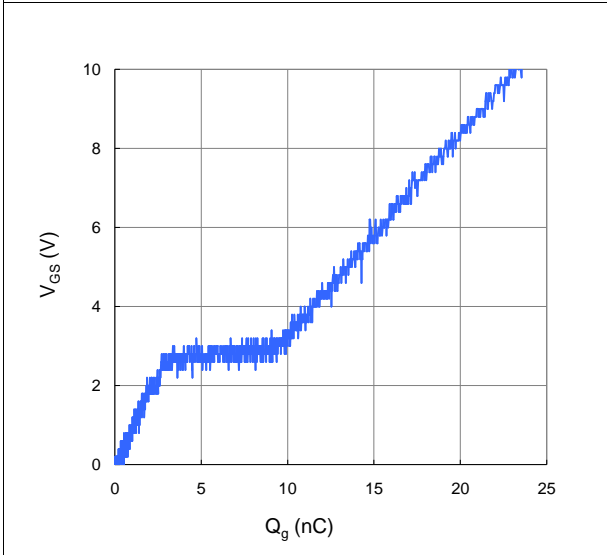

Figure 8. Typical Capacitance vs. Drain-to-Source Voltage

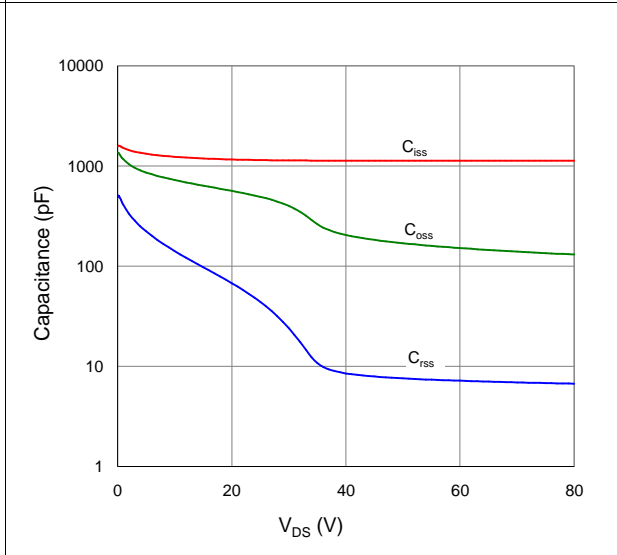

Figure 9. Maximum Safe Operating Area

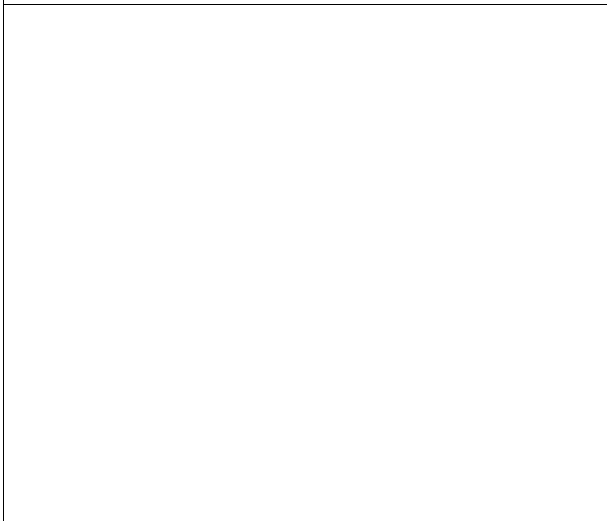

Figure 10. Maximum Drain Current vs. Case Temperature

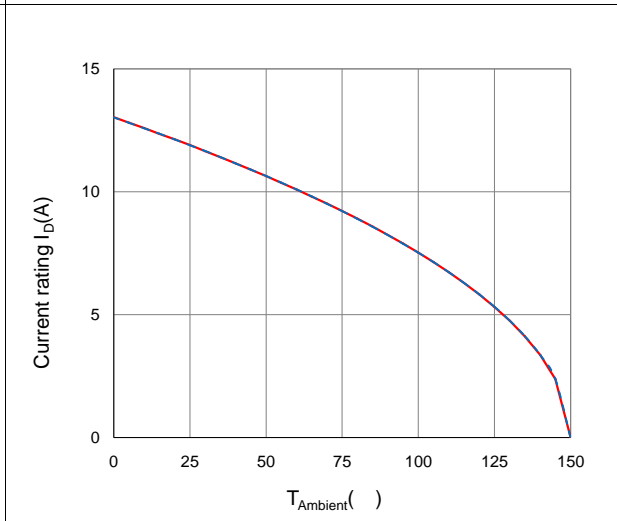
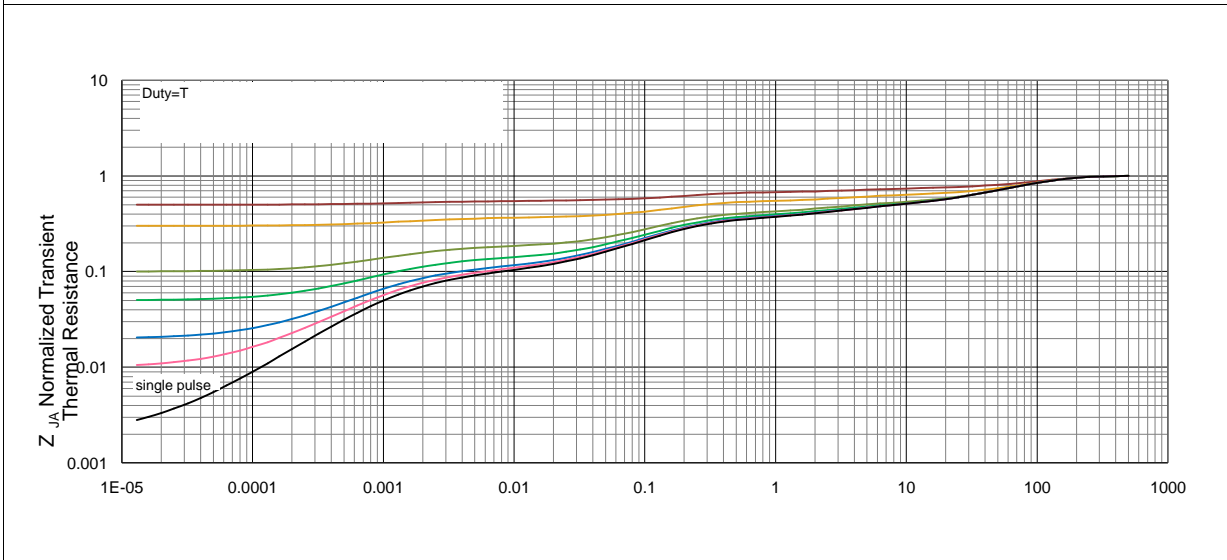
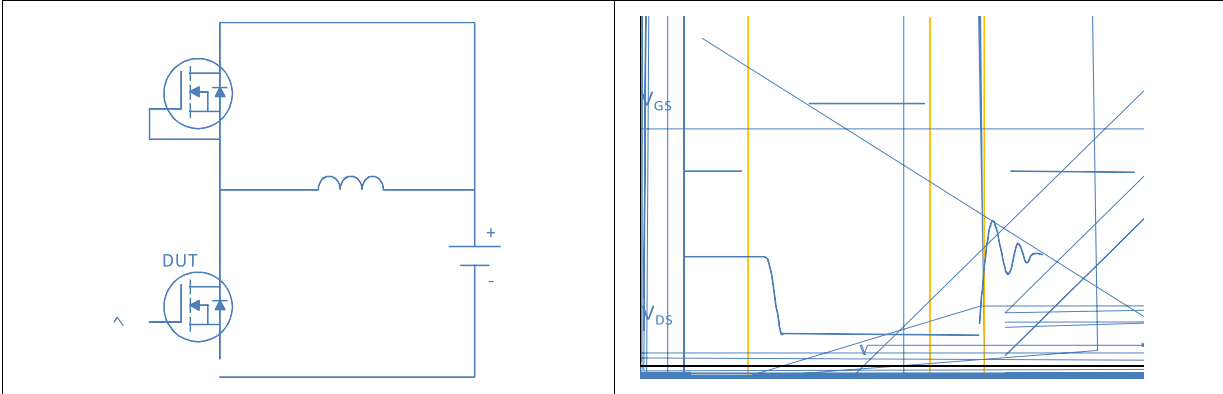

Figure 11. Normalized Maximum Transient Thermal Impedance, Junction-to-Ambient



Inductive switching Test



Gate Charge Test

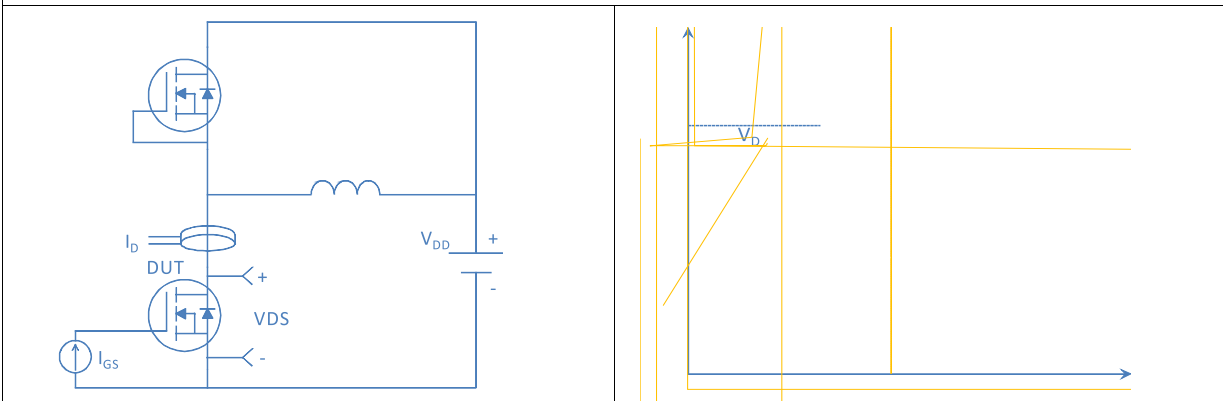

Uclamped Inductive Switching (UIS) Test

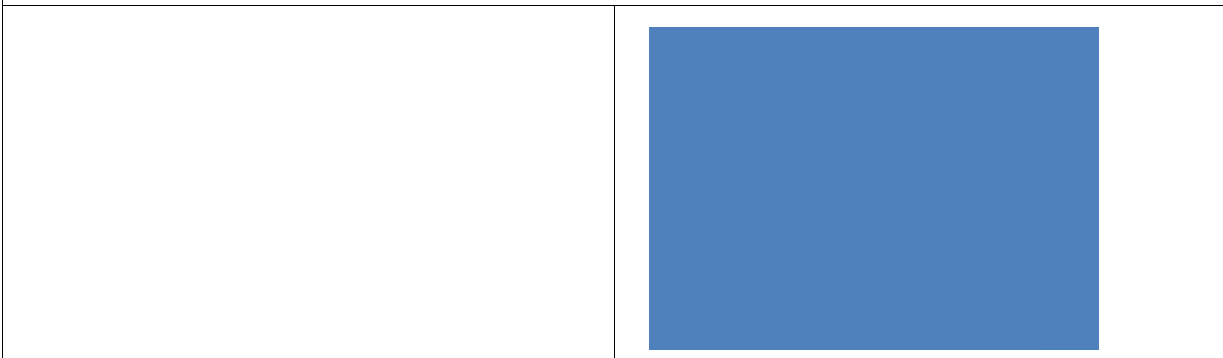

Diode Recovery Test

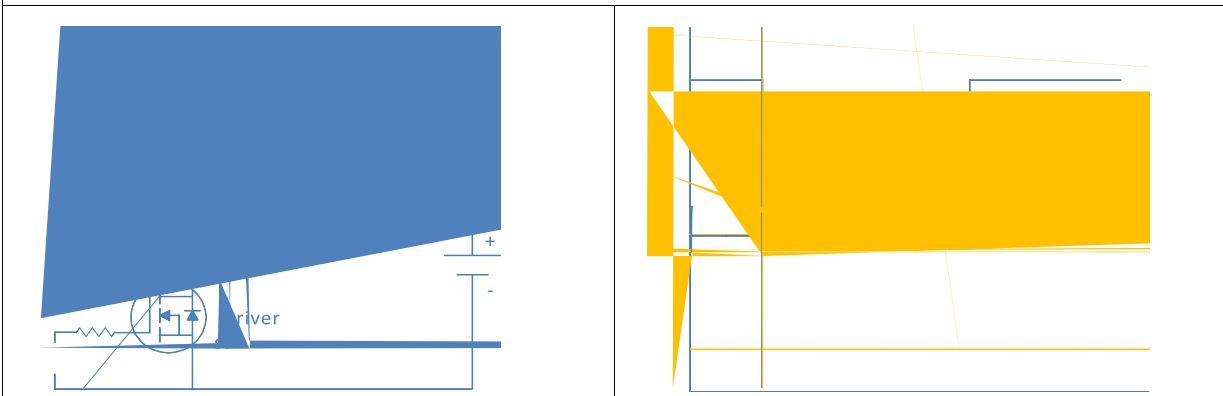

Package Outline

SOIC-8, 8 leads

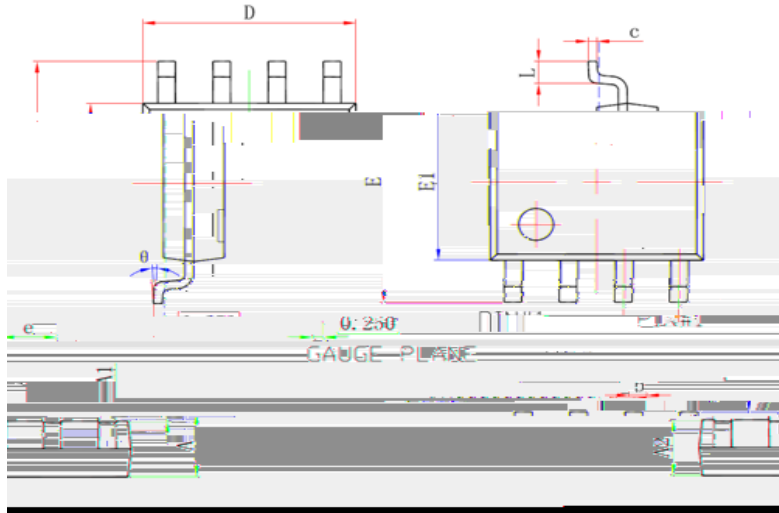

Symbol	Dimensions In Millimeters		Dimensions In Inches	
	Min	Max	Min	Max
A	1.350	1.750	0.053	0.069
A1	0.100	0.250	0.004	0.010
A2	1.250	1.650	0.049	0.065
b	0.310	0.510	0.012	0.020
c	0.170	0.250	0.007	0.010
D	4.800	5.000	0.189	0.197
e	1.270 (BSC)		0.050 (SBC)	
E	5.800	6.200	0.228	0.244
E1	3.800	4.000	0.150	0.157
L	0.400	1.270	0.016	0.031
θ	0°	8°	0°	8°